

NEW SIZES!

PATENT NO. 1015113

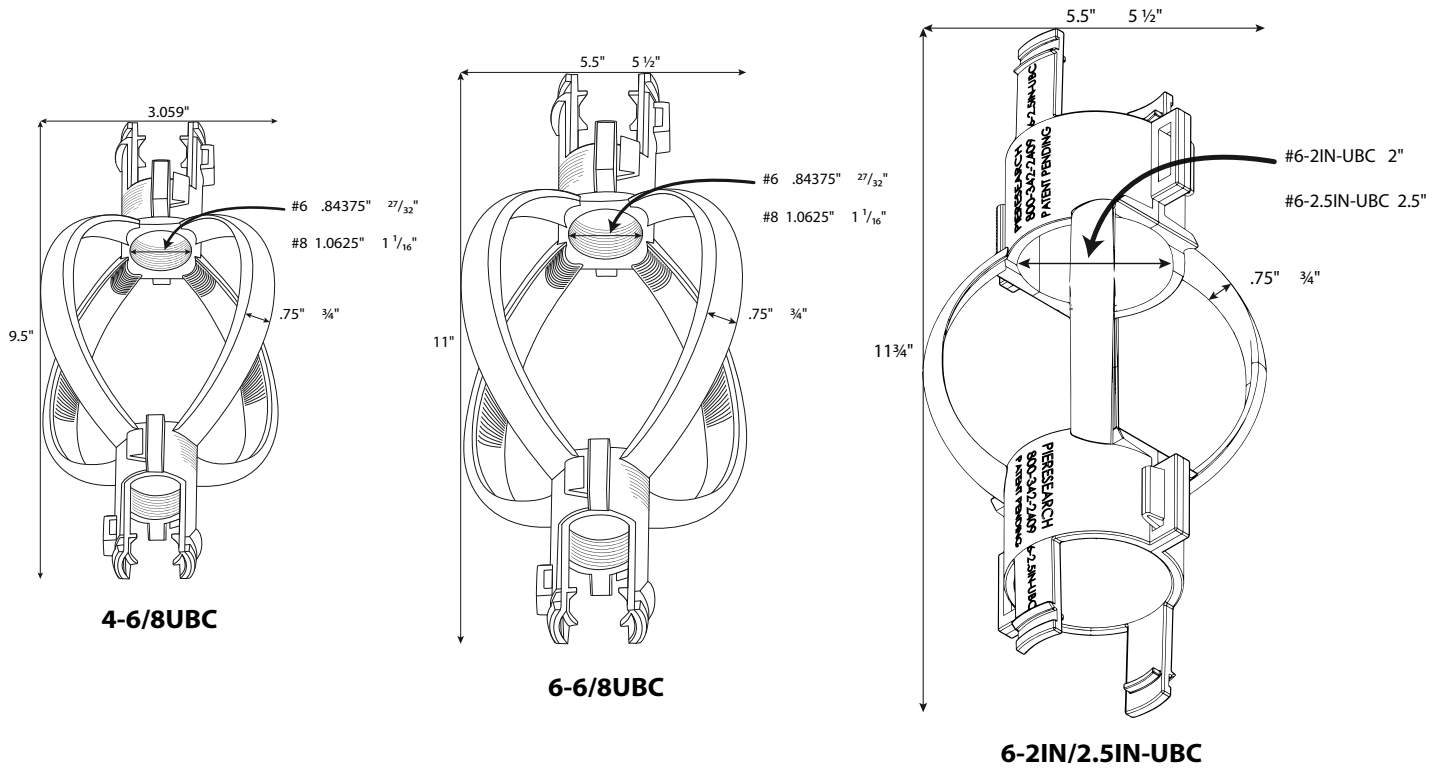

PIERESEARCH UNIBAR SPECS • SECTION 31 32 39 SOIL NAILING ACCESSORIES

PART 1 - GENERAL

1.1 SUMMARY

- A. Section Includes: Soil nailing tendon accessories indicated, specified, or required to complete installation.

1.2 SUBMITTALS

- A. Product Data: Manufacturer's technical literature for each type of manufactured material and product specified.
- B. Certification: Manufacturer's written certification that products furnished comply with or exceed specified requirements.

1.3 QUALITY ASSURANCE

- A. Manufacturer Qualifications: Company specializing in manufacturing products specified with minimum of three years documented experience.

1.4 DELIVERY, STORAGE, AND HANDLING

- A. Store and handle materials to prevent damage.

PART 2 - PRODUCTS

2.1 MANUFACTURER

- A. PIERESEARCH, 501 East Main Street, Arlington TX, 76010; phone (800) 342-2409; (817) 277-3738; Fax (817) 275-2335; www.pieresearch.com.
- B. For manufacturers not listed, submit as substitution according to the Conditions of the Contract and Division 01 Specification Sections.

2.2 TENDON CENTRALIZERS (QUICK-LOCK™ UNIBAR™ CENTRALIZERS)

- A. Description:
 1. Centralizer is made of plastic and are two identical halves that can be easily snapped together around soil nail tendon.
 2. Centralizer keeps soil nail tendon centered in drilled shaft and does not impede flow of grout/concrete.
 3. Centralizer Part Number:

NOTE TO SPECIFIER: SELECT ONE OF THE FOLLOWING OPTIONS

Part No.	Description
4-2IN-UBC	4" O.D. with 2" I.D. Hub
4-2.5IN-UBC	4" O.D. with 2.5" I.D. Hub
6-2IN-UBC	6" O.D. with 2" I.D. Hub
6-2.5IN-UBC	6" O.D. with 2.5" I.D. Hub

42 per box. Box weight approx. 15 pounds.
1,470 parts per pallet.

Part No.	Description
4-6UBC	4" O.D. fits rebar sizes #5 thru #6
4-8UBC	4" O.D. fits rebar sizes #7 thru #8
4-1.5IN-UBC	4" O.D. with 1.5" I.D. Hub
6-6UBC	6" O.D. fits rebar sizes #5 thru #6
6-8UBC	6" O.D. fits rebar sizes #7 thru #8
6-1.5IN-UBC	6" O.D. with 1.5" I.D. Hub

60 parts per box. Box weight approx. 14 pounds.
1,800 parts per pallet.

EXECUTION

2.3 INSTALLATION

- A. Attach centralizers to soil nail tendon according to manufacturer's instructions.
- B. Snap two identical halves together around tendon and secure with tie wire or zip tie.
- C. Attachment Locations:
 1. At deep end of drilled shaft, attach centralizer at approximately 1 foot from end of the soil nail tendon.
 2. Attach centralizer at maximum 10 foot intervals along total length of soil nail tendon.
 3. At access end of drilled shaft, attach centralizer so that it will be approximately 1 foot below grout/concrete surface.
- D. To prevent sliding, secure centralizer to soil nail tendon with tie wire or zip tie threaded through end tab slots.